



MOP-TFT320240-35G-BLM-TPC

Hardware Manual

Revision 1.3

Revision History

Revision	Date	Description	Author
1.3	March 25, 2019	Corrected Touch FFC pinout	Divino
1.2	June 27, 2018	Added FFC information	Divino
1.1	March 29, 2018	Updated Naming Convention	Divino
1.0	May 26, 2017	Initial Release	Divino



Contents

- Revision History 1
- Contents 2
- 1 General Information 3
- 2 Absolute Maximum Ratings..... 3
- 3 Electrical Characteristics..... 3
- 4 Backlight Characteristics..... 3
- 5 Touch Panel Characteristics 4
- 6 External Dimensions 5
- 7 Electro-Optical Characteristics 6
- 8 Interface Description 7
 - 8.1 LCM Interface Description 7
 - 8.2 Capacitive Touch Panel Interface Description 7
- 9 AC Characteristics 8
 - 9.1 Pixel Timing..... 8
 - 9.2 Data Timing..... 9
- 10 Power Sequence 10
 - 10.1 Power Up Sequence 10
 - 10.2 Power Down Sequence..... 11
- 11 Inspection Criterion 12
 - 11.1 Description 12
 - 11.2 Sample plan 12
 - 11.3 Inspection condition 12
 - 11.4 Definition of inspection zone in LCD..... 12
 - 11.5 Function Defect 12
 - 11.6 LCD pixel defect 13
 - 11.7 Dot and line defect 13
- 12 Handling Precautions..... 14
 - 12.1 Mounting method 14
 - 12.2 LCD Handling and Cleaning Precaution 14
 - 12.3 Static Charge Precaution 14
 - 12.4 Packing..... 14
 - 12.5 Precautions during Operation 14
 - 12.6 Storage Recommendations 15
 - 12.7 Safety Precautions 15
- 13 Ordering 16
 - 13.1 Part Numbering Scheme..... 16
 - 13.2 Options 16
- 14 Contact 16



1 General Information

No.	Item	Contents	Unit
1	LCD size	3.5 inch (Diagonal)	/
2	LCD type	TN/Normally white/Transmissive	/
3	Viewing direction(eye)	12 O'clock	/
4	Gray scale inversion direction	6 O'clock	/
5	Resolution(H*V)	320*240 Pixels	/
6	Module size (L*W*H)	76.9*63.9*5.1	mm
7	Active area (L*W)	70.08*52.56	mm
8	Pixel pitch (L*W)	0.219*0.219	mm
9	Interface type	RGB interface	/
10	Module power consumption	0.066(without backlight)	W
11	Back light type	LED	/
12	Driver IC	HX8238D or compatible	/
13	Weight	49	g

2 Absolute Maximum Ratings

Item	Symbol	Min	Max	Unit
Power supply input voltage (LCM)	VDD	-0.3	3.6	V
Backlight current (normal temp.)	ILED	-	50	mA
Operation temperature	Top	-20	70	°C
Storage temperature	Tst	-30	80	°C
Humidity	RH	-	90%(Max60 °C)	RH

3 Electrical Characteristics

DC Characteristics (at Ta=25 °C)

Item	Symbol	Min	Typ	Max	Unit
Power supply input voltage (LCM)	VDD	2.5	3.3	-	V
I/O logic voltage	VDDIO	N/A	N/A	N/A	V
Input voltage 'H' level	VIH	0.7VDD	-	VDD	V
Input voltage 'L' level	VIL	VSS	-	0.3VDD	V
Power supply current	IVDD	-	20	-	mA
TFT gate on voltage	VGH	-	N/A	-	V
TFT gate off voltage	VGL	-	N/A	-	V
Analog power supply voltage	AVDD	-	N/A	-	V
Differential input common mode voltage	Vcom	-	N/A	-	V

4 Backlight Characteristics

(at Ta=25 °C, RH=60%)

Item	Symbol	Min.	Typ.	Max.	Unit	Note
LED forward voltage	VF	-	9.6	10.2	V	IF=20*2mA
LED forward current	IF	-	40	-	mA	
LED power consumption	PLED	-	0.384	-	W	*Note
Number of LED	-	6			PCS	
Connection mode	-	3 in series, 2 in parallel			/	
LED life-time	-	20000	-	-	Hrs	**Note

***Note:** Calculate Value for reference ILED×VLED×LED Quantity = PLED

****Note:** The LED Life-time is defined as the estimated time to 50% degradation of initial brightness at Ta=25°C and IF =40mA. The LED lifetime could be decreased if operating IF is larger than 40mA, and increased if IF is less than 40mA.



5 Touch Panel Characteristics

(at Ta=25 °C)

Item	Description
IC solution on TP Model	FT5416
Touch Count Max	5 point
Display Resolution	320*240
Interface Type	I2C
I2C Slave Address	0x70
Origin of Coordinate	top left corner
Hardness	6H

Parameter	Min	Typ	Max	Unit
Interface Signal Voltage	-	3.0	-	V
Power Voltage	2.8	3.0	3.3	V
Power ripple	-	-	50	mV



6 External Dimensions

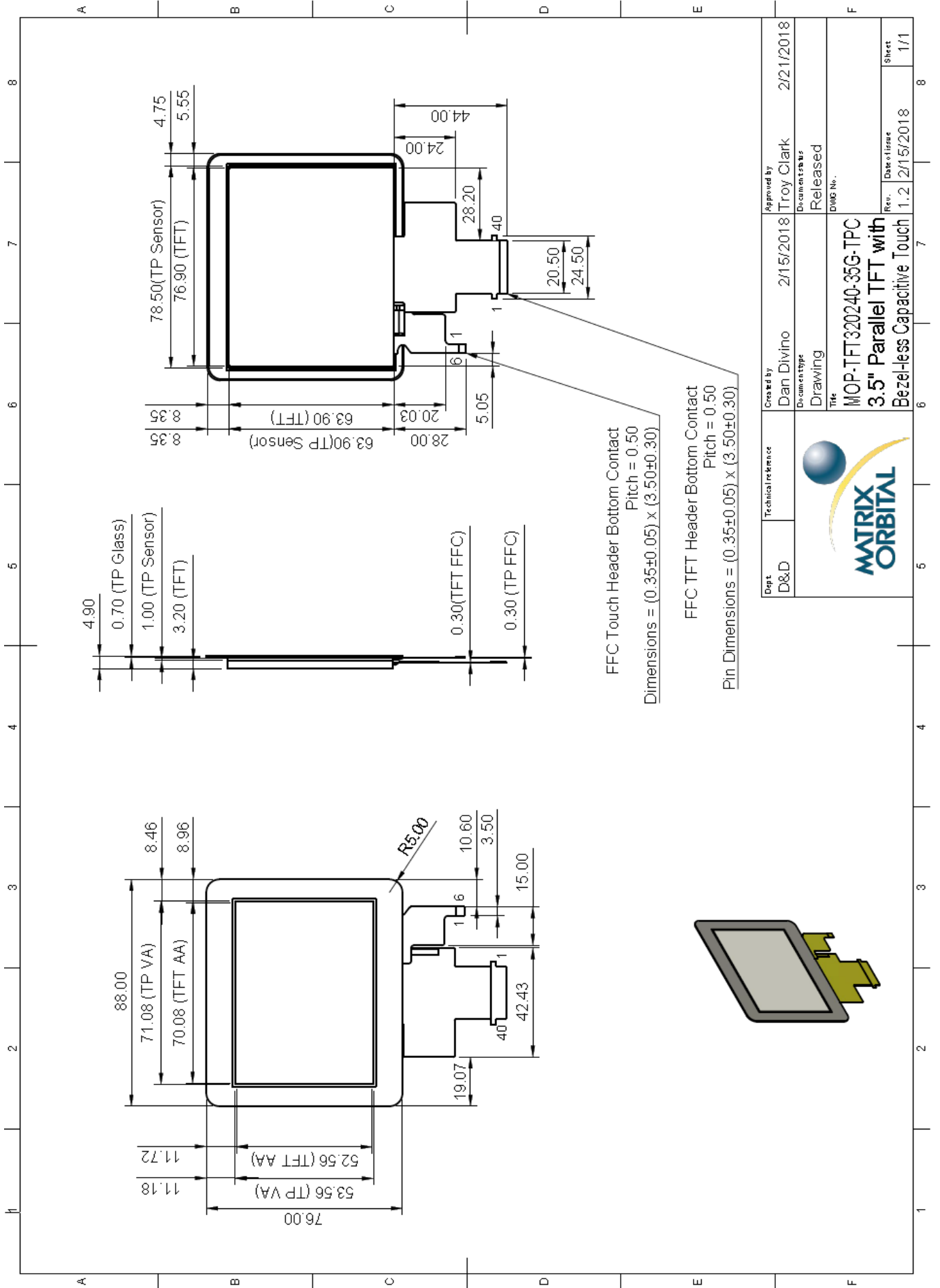

Figure 1: MOP-TFT320240-35G-BLM-TPC Drawing



7 Electro-Optical Characteristics

Item	Symbol	Condition	Min	Typ	Max	Unit	Remark	Note
Response time	Tr + Tf	-	-	50	80	ms	FIG 1.	Note 4
Contrast ratio	Cr		200	300	-	---	FIG 2.	Note 1
Surface luminance	Lv	$\theta=0^\circ$	350	495	-	cd/m ²	FIG 2.	Note 2
Luminance uniformity	Yu	$\theta=0^\circ$	75	80	-	%	FIG 2.	Note 3
NTSC	-	$\theta=0^\circ$	-	60	-	%	FIG 2.	Note 5
Viewing angle	θ	$\varnothing = 90^\circ$	50	60	-	deg	FIG 3.	Note 6
		$\varnothing = 270^\circ$	40	50	-	deg	FIG 3.	
		$\varnothing = 0^\circ$	50	60	-	deg	FIG 3.	
		$\varnothing = 180^\circ$	50	60	-	deg	FIG 3.	
CIE (x, y) chromaticity	Red x	$\theta=0^\circ$ $\varnothing=0^\circ$ Ta=25°C	0.5706	0.6106	0.6506	-	FIG 2. CIE1931	Note 5
	Red y		0.3254	0.3654	0.4054	-		
	Green x		0.3000	0.3400	0.3800	-		
	Green y		0.5649	0.6049	0.6449	-		
	Blue x		0.1074	0.1474	0.1874	-		
	Blue y		0.0387	0.0787	0.1187	-		
	White x		0.2632	0.3032	0.3432	-		
	White y		0.2829	0.3229	0.3629	-		

***Note 1:** Definition of contrast ratio

Contrast Ratio (CR) is defined mathematically by the following formula.

$$\text{CONTRAST RATIO} = \frac{\text{Luminance measured when LCD on the "White" State}}{\text{Luminance measured when LCD on the "Black" State}}$$

***Note 2:** Definition of surface luminance

Surface luminance is the LCD luminance from the surface with all pixels displaying white.

$$L_v = \text{Average Surface Luminance with all white pixels (P1, P2, P3 ... Pn)}$$

***Note 3:** Definition of luminance uniformity

The luminance uniformity in surface luminance (Yu) is determined by measuring luminance at each test position 1 through n, and then dividing the maximum luminance of n point's luminance by minimum luminance of n points luminance.

$$Y_u = \frac{\text{Minimum Surface Luminance with all white pixels (P1, P2, P3 ... Pn)}}{\text{Maximum Surface Luminance with all white pixels (P1, P2, P3 ... Pn)}}$$

***Note 4:** Definition of Response time

The response time is defined as the LCD optical switching time interval between "White" state and "Black" state. Rise time (TON) is the time between photo detector output intensity changed from 90% to 10%. And fall time (TOFF) is the time between photo detector output intensity changed from 10% to 90%.

***Note 5:** Definition of color chromaticity (CIE1931)

CIE (x, y) chromaticity, the x, y value is determined by screen active area center position P5.

***Note 6:** Definition of Viewing angle.

Viewing angle is the angle at which the contrast ratio is greater than 10. The angles are determined for the horizontal or x axis and the vertical or y axis with respect to the z axis which is normal to the LCD surface.

For Viewing angle and response time testing, the testing data is based on Autronic-Melchers's ConoScope or DMS series Instruments or compatible. For contrast ratio, Surface Luminance, Luminance uniformity and CIE, the testing data is based on TOPCON's BM-7 or BM-5 photo detector or compatible.

***Note 7:** For TFT module, Gray scale reverse occurs in the direction of panel viewing angle.



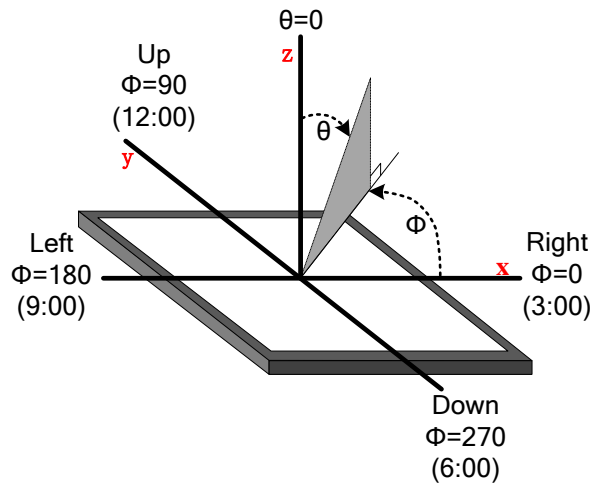

Figure 2: The definition of viewing angle

8 Interface Description

8.1 LCM Interface Description

The MOP-TFT320240-35G-BLM-TPC uses a FFC cable for 24bit RGB parallel communication. The FFC cable is compatible with any 40 position FFC connector with a 0.5mm pitch and Top/Bottom contacts such as the Omron Electronics Inc XF2M-4015-1A.

Interface No.	Name	I/O Pin Connections	Description
1	LEDK	P	Power for LED backlight(Cathode)
2	LEDA	P	Power for LED backlight(Anode)
3	CS	I	Chip select pin
4	VDD	P	Power for LCD
5-12	Red(0-7)	I	Red data
13-20	Green(0-7)	I	Green data
21-28	Blue(0-7)	I	Blue data
29	GND	I	Ground
30	DCLK	I	Dot-clock signal
31	DISP	I	Display on/off
32	HSYNC	I	Horizontal sync input.
33	VSYNC	I	Vertical sync input
34	DE	I	Data enable
35	SCL	I	Clock pin of serial interface
36	SDA	I/O	Data input pin in serial mode
37	XR(NC)	-	No connection
38	YD(NC)	-	No connection
39	XL(NC)	-	No connection
40	YU(NC)	-	No connection

8.2 Capacitive Touch Panel Interface Description

The capacitive touch panel uses a 6 pin FFC cable to relay touch information to the host. The FFC cable is compatible with any 6 position connector with a 0.5mm pitch and top/Bottom contacts such as the Molex, LLC 5034800600.

Interface No.	Name	I/O Pin Connection	Description
1	RESET	I	Reset low
2	INT	O	State change interrupt
3	GND	P	Ground
4	SDA	I/O	Serial interface data
5	SCL	I	Serial interface clock
6	VCC	P	Power Supply of CTP



9 AC Characteristics

9.1 Pixel Timing

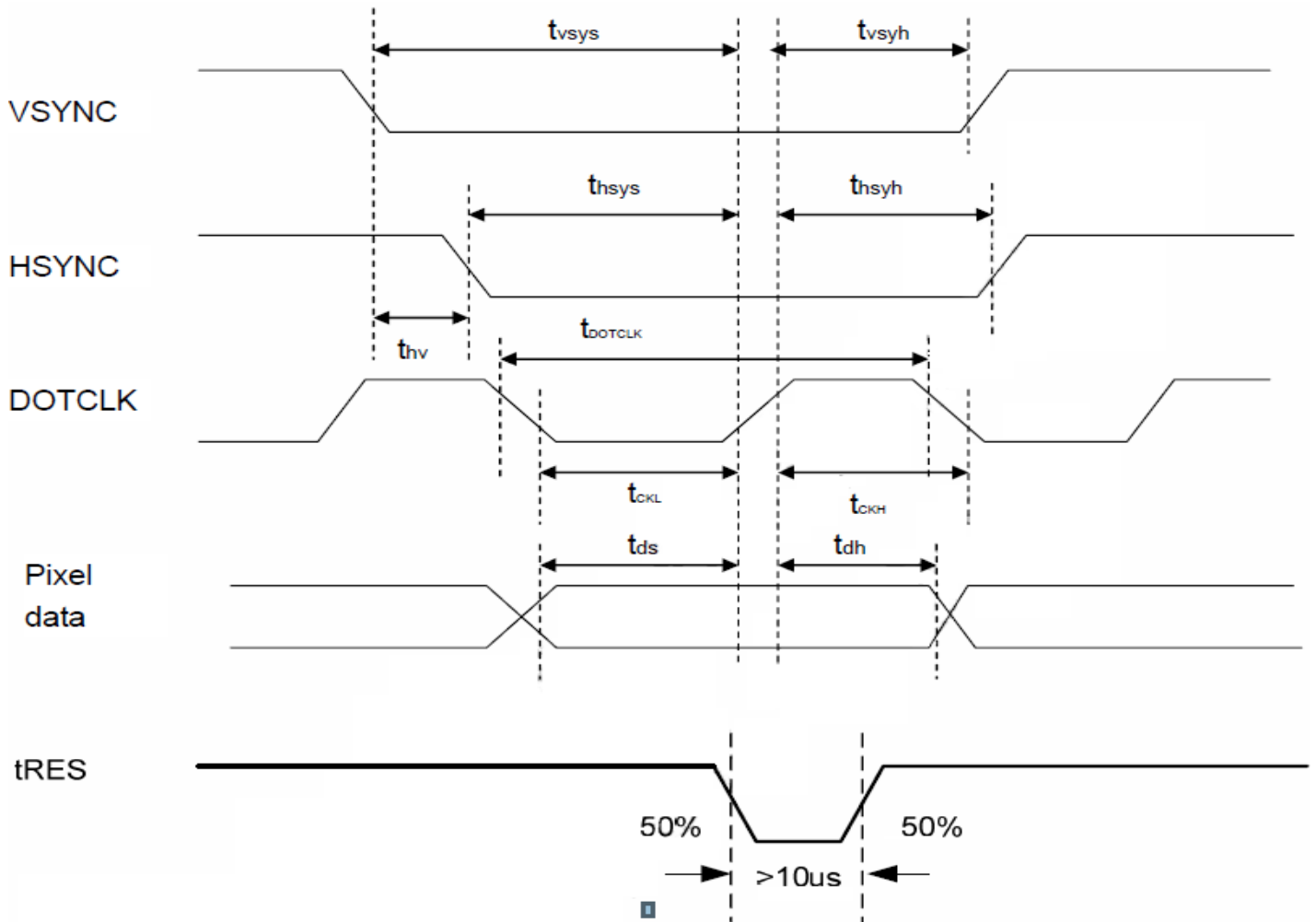

Figure 3: Pixel Timing

Characteristics	Symbol	Min.		Typ.		Max.		Unit
		24 bit	8 bit	24 bit	8 bit	24 bit	8 bit	
DOTCLK Frequency	fDOTCLK	-	-	6.5	19.5	10	30	MHz
DOTCLK Period	tDOTCLK	100	33.3	154	51.3	-	-	ns
Vertical Sync Setup Time	tvsys	20	10	-	-	-	-	ns
Vertical Sync Hold Time	tvsyh	20	10	-	-	-	-	ns
Horizontal Sync Setup Time	thsys	20	10	-	-	-	-	ns
Horizontal Sync Hold Time	thsyh	20	10	-	-	-	-	ns
Phase Difference of Sync Signal Falling Edge	thv	1		-		240		tDOTCLK
DOTCLK Low Period	tCKL	50	15	-	-	-	-	ns
DOTCLK High Period	tCKH	50	15	-	-	-	-	ns
Data Setup Time	tds	12	10	-	-	-	-	ns
Data Hold Time	tdh	12	10	-	-	-	-	ns
Reset pulse width	tRES	10		-		-		µs

*Note: External clock source must be provided to DOTCLK pin of HX8238-D. The driver will not operate if absent of the clocking signal.



9.2 Data Timing

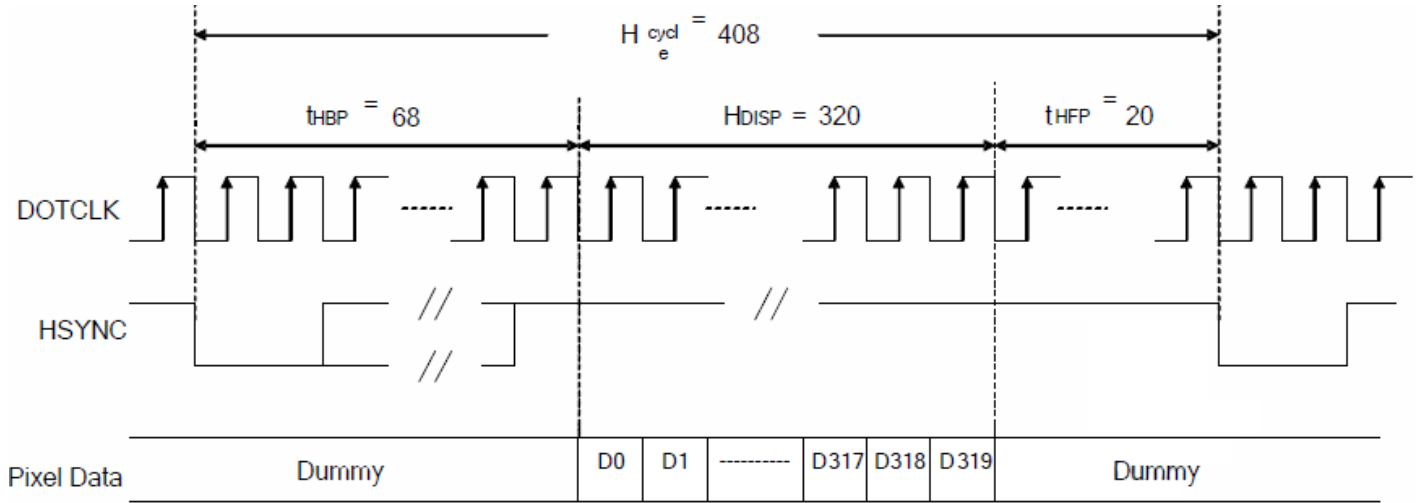

(a) Horizontal Data Transaction Timing

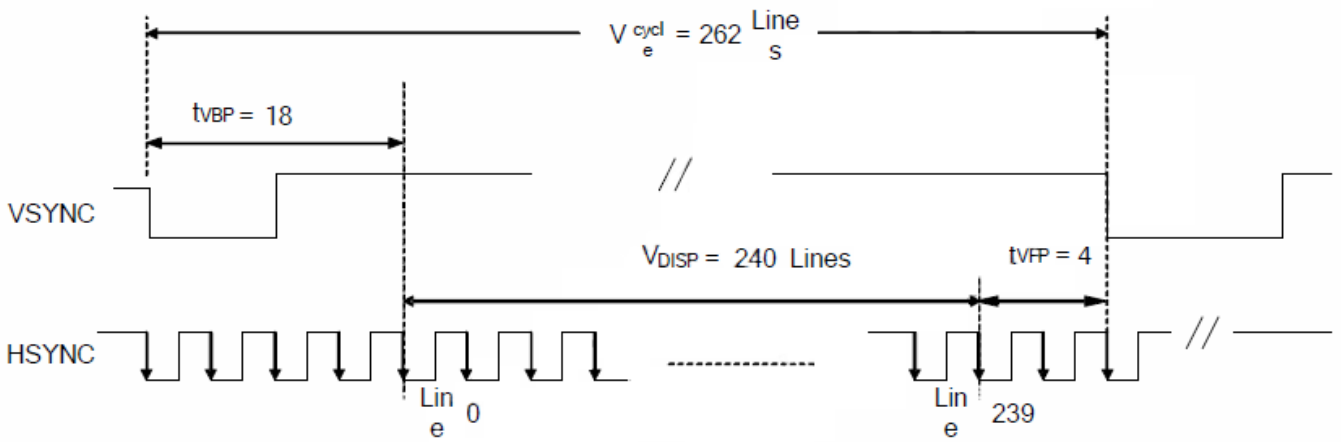

(b) Vertical Data Transaction Timing

Figure 4: Data Transaction Timing in Parallel RGB (24Bit) interface (SYNC Mode)

Characteristics	Symbol	Min.		Typ.		Max.		Unit
		24 bit	8 bit	24 bit	8 bit	24 bit	8 bit	
DOTCLK Frequency	fDOTCLK	-	-	6.5	19.5	10	30	MHz
DOTCLK Period	tDOTCLK	100	33.3	154	51.3	-	-	ns
Horizontal Frequency (Line)	fH	-	-	14.9	-	22.35	-	KHz
Vertical Frequency (Refresh)	fV	-	-	60	-	90	-	Hz
Horizontal Back porch	tHBP	-	-	68	204	-	-	tDOTCLK
Horizontal Front porch	tHFP	-	-	20	60	-	-	tDOTCLK
Horizontal Data Start Point	tHBP	-	-	68	204	-	-	tDOTCLK
Horizontal Blanking Period	tHBP + tHFP	-	-	88	264	-	-	tDOTCLK
Horizontal Display Area	HDISP	-	-	320	960	-	-	tDOTCLK
Horizontal Cycle	Hcycle	-	-	408	1224	450	1350	tDOTCLK
Vertical Back Porch	tVBP	-	-	18	-	-	-	Lines
Vertical Front Porch	tVFP	-	-	4	-	-	-	Lines
Vertical Data Start Point	tVBP	-	-	18	-	-	-	Lines
Vertical Blanking Period	tVBP + tVFP	-	-	22	-	-	-	Lines
Vertical Display Area	NTSC	-	-	240		-	-	Lines
	PAL			280(PALM=0)				
	PAL			288(PALM=1)				
Vertical Cycle	NTSC	-	-	262		350	-	Lines
	PAL			313				



10 Power Sequence

10.1 Power Up Sequence

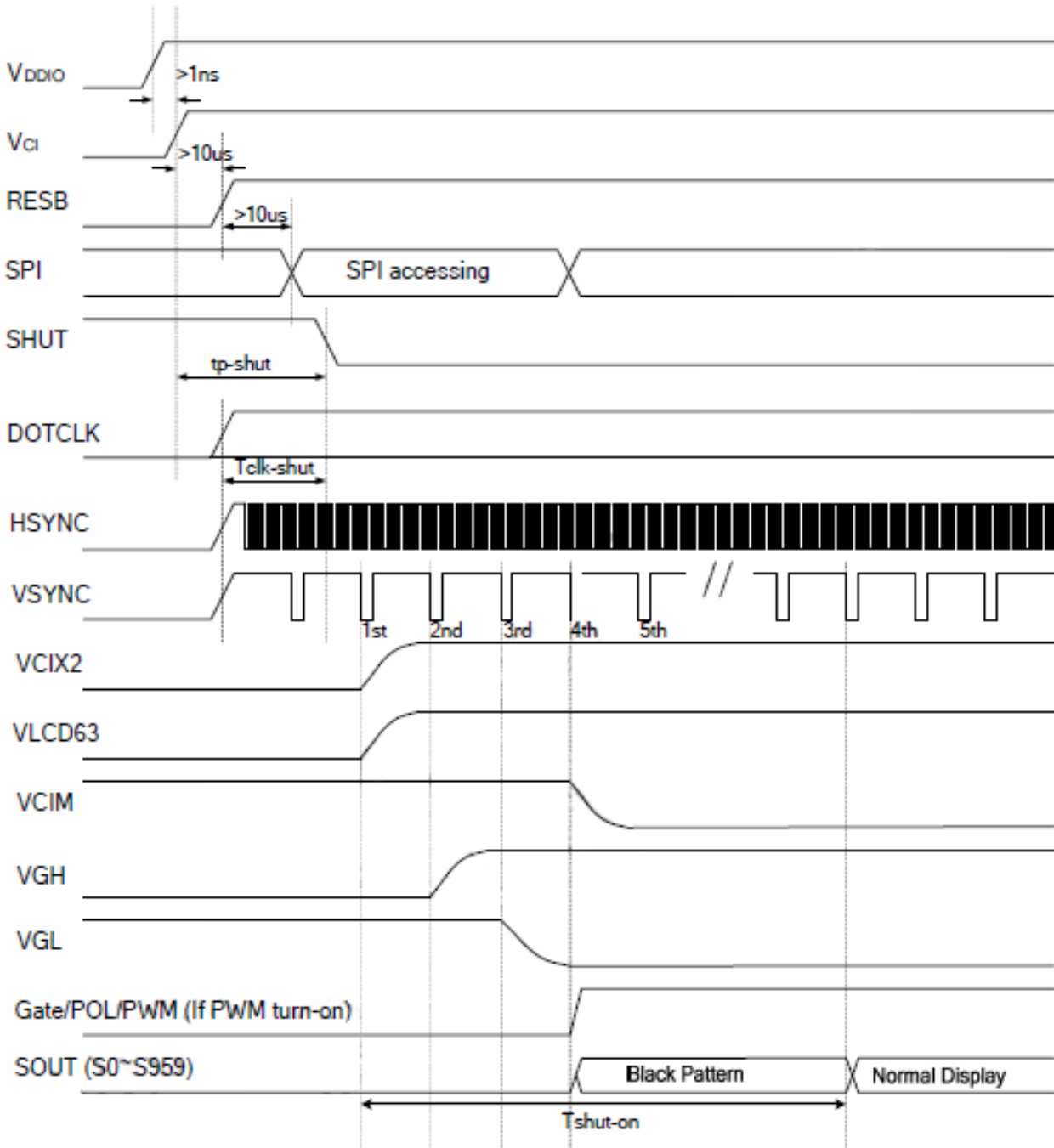

Figure 5: Power Up Sequence

Characteristics	Symbol	Spec.			Unit
		Min.	Typ.	Max.	
VDD/VDDIO on to falling edge of SHUT	tp-shut	1	-	-	μs
DOTCLK	tclk-shut	1	-	-	clk
Falling edge of SHUT to display start	tshut-on	-	-	14	frame
- 1 line: 408 CLK - 1 frame: 262 line - DOTCLK = 6.5MHz		-	166	232.4	ms

***Note:** it is necessary to input DOTCLK before the falling edge of SHUT. Display starts at 10th falling edge of VSYNC after the falling edge of SHUT



10.2 Power Down Sequence

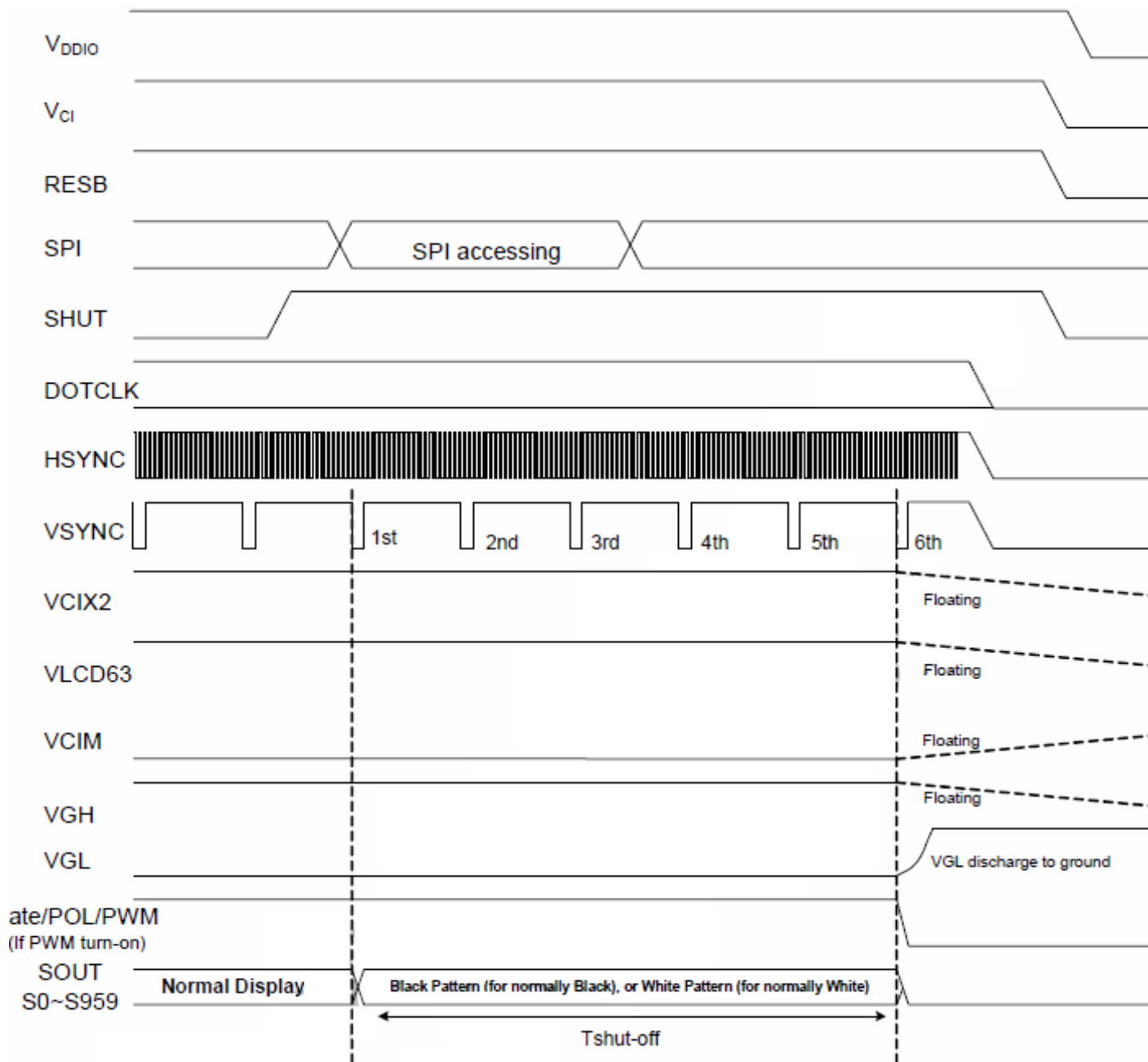

Figure 6: Power Down Sequence

Characteristics	Symbol	Spec.			Unit
		Min.	Typ.	Max.	
Rising edge of SHUT to display off	tshut-off	2	-	-	frame
- 1 line: 408 CLK - 1 frame: 262 line - DOTCLK = 6.5MHz		33.4	-	-	ms

***Note:** DOTCLK must be maintained at least 2 frames after the rising edge of SHUT. Display turns off at the 2nd falling edge of VSYNC after the falling edge of SHUT. If RESET signal is necessary for power down, provide it after the 2- frames-cycle of the SHUT period.



11 Inspection Criterion

11.1 Description

This specification is made to be used as the standard acceptance/rejection criteria for the MOP-TFT320240-35G-BLM-TPC.

11.2 Sample plan

Sampling plan according to GB/T2828.1-2003/ISO 2859-1: 1999 and ANSI/ASQC Z1.4-1993, normal level 2 and based on:

Major defect: AQL 0.65

Minor defect: AQL 1.5

11.3 Inspection condition

- Viewing distance for cosmetic inspection is about $30\pm 5\text{cm}$ with bare eyes, and under a $600\sim 1000\text{lux}$ environment for visual inspection and $0\sim 200\text{lux}$ for function test. All directions for inspecting the sample should be within 45° against perpendicular line. (Normal temperature $18\sim 28^\circ\text{C}$ and normal humidity $60\pm 15\%\text{RH}$).
- During testing, the LCD is driven using the voltage level (Within $\pm 0.5\text{V}$ of the typical value at 25°C .) that provides the most optical contrast

11.4 Definition of inspection zone in LCD

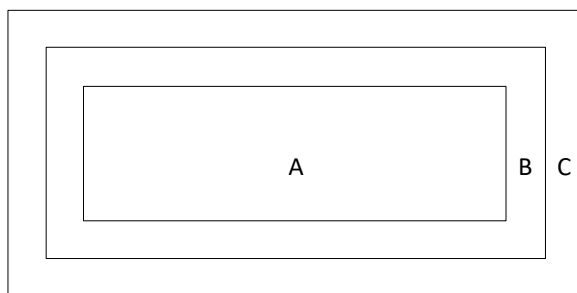

Figure 7: Inspection Zones in an LCD

Zone A: character/Digit area

Zone B: viewing area except Zone A (Zone A + Zone B=minimum Viewing area)

Zone C: Outside viewing area (invisible area after assembly in customer's product)

***Note:** As a general rule, visual defects in Zone C are permissible, if it does not affect display quality and assembly of customer's product.

11.5 Function Defect

Items to be inspected	Inspection criterion	Classification of defects
All functional defects	1) No display 2) Display abnormally 3) Missing vertical, horizontal segment 4) Short circuit 5) Back-light no lighting, flickering and abnormal lighting. 6) obvious striation 7) Current beyond specification value	MA
Missing	Missing component	
Outline dimension	Overall outline dimension exceed the drawing is not allowed.	



11.6 LCD pixel defect

(bad dot) (defect type: MI)

Checking item	Judgment criterion
Color bad dot-bright dot(R,G,B)	1
Two adjacent bright point	0
Three or more adjacent point	0
Total points for bad dot-bright dot	1
Bad dot-dark dot	2
Two adjacent dark point	1
Three or more adjacent point	0
Total points for bad dot -dark dot	3
Patch bright dot	Invisible with ND5%, it is OK.

11.7 Dot and line defect

(defect type: MI)

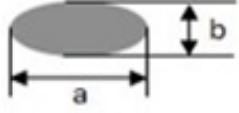
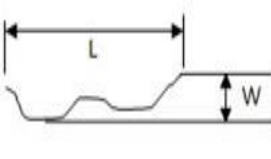
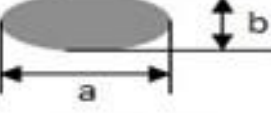
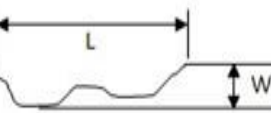
Checking item	Judgment criterion			Figure
	Diameter(mm)\LCD Size		S ≤5.0 Inch	
Dot defect	D ≤0.1		allowed	 $D=(a+b)/2$
	0.1 < D ≤0.2		4	
	0.2 < D ≤0.3		0	
	0.3 < D ≤0.5		0	
	D >0.5		0	
	the distance between the two defect dot: DS ≥5mm			
Line defect	Length(mm)	Width(mm)	Judgement Criterion	
	disregard	W ≤0.05	allowed	
	L ≤5	0.05 < W ≤0.1	4	
	L >5	W >0.1	0	
Concave point and air bubble for polarizer	Size(mm)		Judgement Criterion	 $D=(a+b)/2$
	D ≤0.3		allowed	
	0.3 < D ≤1.0		3	
	1.0 < D ≤1.5		1	
	D >1.5		0	
Fold mark, linear scar for polarizer	Length(mm)	Width(mm)	Judgement Criterion	
	disregard	W ≤0.05	allowed	
	1 < L ≤5	0.05 < W ≤0.2	3	
	L >5	W >0.2	0	
<p>*Notes:</p> <ol style="list-style-type: none"> 1. If the fold mark and linear scar for polarizer is visible with operating condition, the defect is judged with line judge 2. If the fold mark and linear scar for polarizer is visible with non-operating condition, the defect is judged with the above judgment standard. 				



12 Handling Precautions

12.1 Mounting method

Do not make extra holes in the display or modify its shape. When mounting the display, ensure that the display does not flex, bend or twist. Extreme care should be used when handling the LCD modules.

12.2 LCD Handling and Cleaning Precaution

To clean the display surface, it is recommended to wipe lightly using a soft cloth with either Isopropyl alcohol or Ethyl alcohol.

Do not wipe the display surface with dry or hard materials as it may damage the polarizer surface.

Do not use Water or Aromatics to clean the display.

Do not wipe ITO pad area with dry or hard materials that will damage the ITO patterns

Do not use Soldering flux, Chlorine(Cl), and Sulfur(S) on the pad or prevent it from being contaminated.

If the display is sent without applying a silicon coat on the pad, the ITO patterns could be damaged due to corrosion as time goes on.

If ITO corrosion occurs due to customer miss-handling, or if the customer applies materials such as Chlorine (Cl), Sulfur (S) to the display, the responsibility is placed the customer.

12.3 Static Charge Precaution

The LCD module uses CMOS LSI drivers, so we recommend that you:

- Connect any unused input terminal to VDD or VSS
- Do not input any signals before power is turned on
- Ground your body, work/assembly areas, and assembly equipment to protect against static electricity.

12.4 Packing

The module employs LCD elements and must be treated as such.

- Avoid intense shock and falls from a height.
- To prevent modules from degradation, do not operate or store them exposed direct to sunshine or high temperature/humidity

12.5 Precautions during Operation

- It is an indispensable condition to drive the LCD module within the specified voltage limits. Applying voltage higher than the limit will reduce the life span of the LCD.
- Using direct drive current should be avoided, as it will induce an electrochemical reaction causing undesirable deterioration.
- The LCD's response time will be delayed when operating at a temperature lower than the suggested operating range. When operating at a temperature higher than the suggested range, the LCD will be noticeably darker. The display will return to normal when it is brought back to the specified operation temperature.
- If the display area is pushed hard during operation, some font may be abnormally drawn but the LCD will return to normal after it is reset.
- Slight dew depositing on terminals can cause an electro-chemical reaction, damaging traces and resulting in an open circuit.

Usage under the maximum operating temperature, 50%Rh or less is required



12.6 Storage Recommendations

When storing the LCD for a prolonged period of time, the following recommendations will help prevent damage or deterioration

- Store the display in an ambient temperature range between 10°C to 30°C, and in a relative humidity of 45% to 75%.
- Do not leave the display exposed to sunlight or fluorescent light.
- Place the display in a polyethylene bag with the opening sealed.
- Ensure that nothing is making contact with the polarizer surface.
- It is recommended to store them in the same packaging that was provided upon purchase

12.7 Safety Precautions

In the case that the LCD glass has shattered, it is recommended to remove any glass pieces, wash off the liquid crystal using either acetone or ethanol, and proceed to burn any remaining display pieces.

If any liquid leaked out of a damaged glass cell, and comes in contact with your hands, please wash it off well with soap and water



13 Ordering

13.1 Part Numbering Scheme

Table 1: Parallel TFT Part Numbering Scheme

MOP	TFT	320	240	35	G	BLM	TPC
1	2	3	4	5	6	7	8

13.2 Options

Table 2: Parallel Part Options

#	Designator	Options
1	Product Line	MOP: Matrix Orbital Parallel Display
2	Screen Type	TFT: Graphic TFT
3	Display Columns	320: Three Hundred Twenty Pixel Columns
4	Display Rows	240: Two Hundred Forty Pixel Rows
5	Display Size	35: 3.5"
6	Display Form Factor	G: G Form Factor
7	Brightness Level	-BLS: Brightness < 300 Nit -BLM: 300 Nit < Brightness < 600 Nit -BLH: 600 Nit < Brightness < 1000 Nit -BLD: Brightness > 1000 Nit
8	Touch Panel Type	TPN: None TPR: Resistive TPC: Capacitive

14 Contact

Sales

Phone: 403.229.2737

Email: sales@matrixorbital.ca

Support

Phone: 403.204.3750

Email: support@matrixorbital.ca

Online

Purchasing: www.matrixorbital.com

Support: www.matrixorbital.ca

